



SUBARU

SUBARU

PART NUMBER: E551SSG300

*INSTALLATION
INSTRUCTIONS*

DESCRIPTION: FORESTER REAR BUMPER UNDER GUARD

KIT CONTENTS:

A.

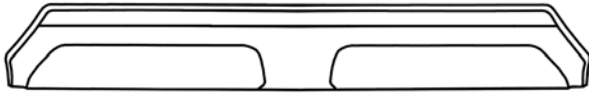

Rear Bumper Under Guard
x 1

B.



Push Retainer
E551SSG310
x 5

C.

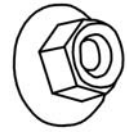

Nut
E551SSG320
x 2

TOOLS REQUIRED:

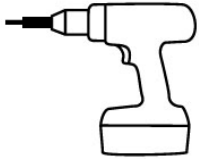

Drill with 5/16" Drill Bit and Drill Stop w/ 1/2" exposure

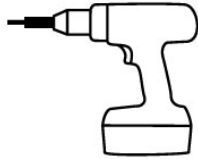

Drill with 1/4" Drill Bit and Drill Stop w/ 1/2" exposure

D.

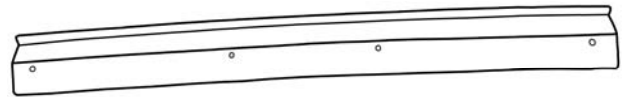

Drill Template
x 1



Torque Wrench with 10mm Socket

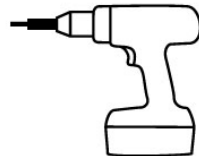

Drill with 3/8" Drill Bit and Drill Stop w/ 1/2" exposure



Alcohol Wipe
x 1

PART NUMBER:
E551SSG300

ISSUE:
01

DATE:
01/31/13

SUBARU OF AMERICA

PAGE
1/8

MEANING OF CHARACTERS:

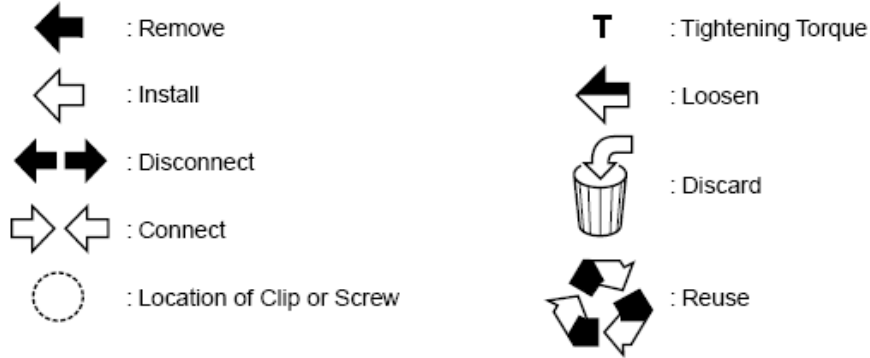

Surface Preparation

- 1** Make sure that all installation surfaces (shown below) are clean, free of dirt, grease, and debris. Use a supplied isopropyl alcohol based wipe. Inspect vehicle for damage before installation of rear bumper under guard. Before beginning, vehicle and under guard must be at room temperature. If the temperature is below 60 F (21 C) or above 110 F (43 C), let vehicle sit indoors until the bumper and under guard are room temperature.

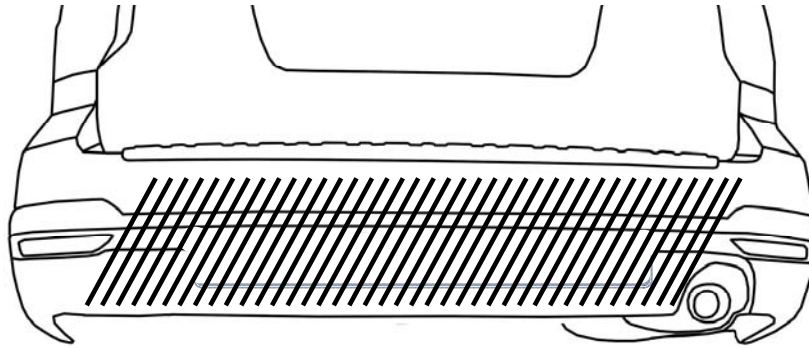

Front Molding Installation

- 2**  Peel tape liners back 1-2" on the drill template (D). Position the drill template in place, aligning with central style and horizontal bumper style lines. Press template lightly onto bumper to hold in place while you check position.

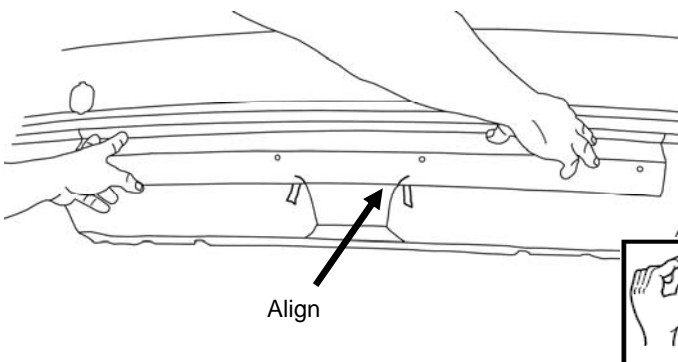

- 3**  Using a measuring tape or a ruler, confirm that the drill template is centered on the bumper. Measure from the end of the drill template to corner of the reflector pocket. *Note: If template is not centered, remove and adjust as needed.* Once template is centered, peel away remaining liners. Apply firm pressure to tape pads.

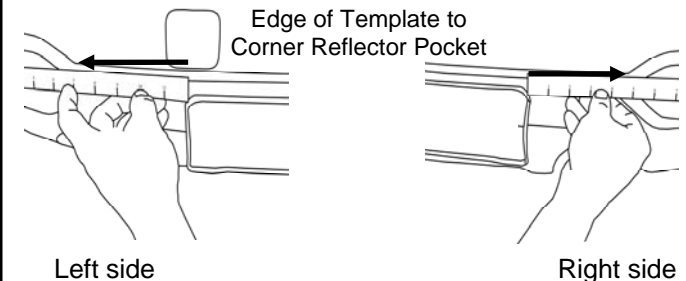

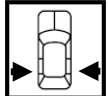
4  Drill two holes in bumper through inner holes on template with 1/4" drill with 1/2" drill stop.

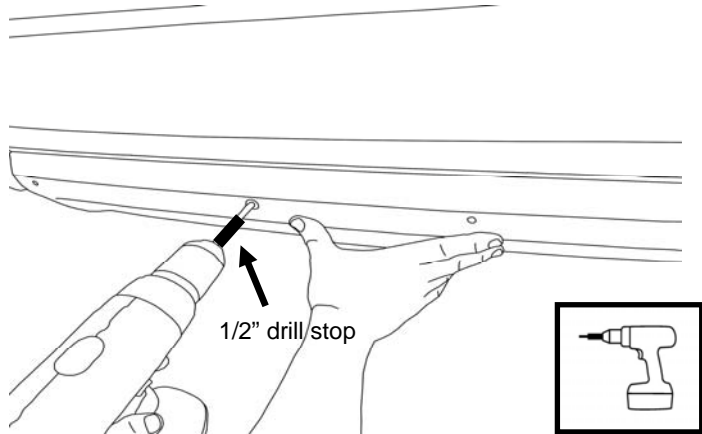

1/2" drill stop

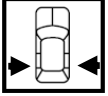
5  Drill two holes in bumper through outer holes on template using a 3/8" drill with 1/2" drill stop. Remove drill template (D).

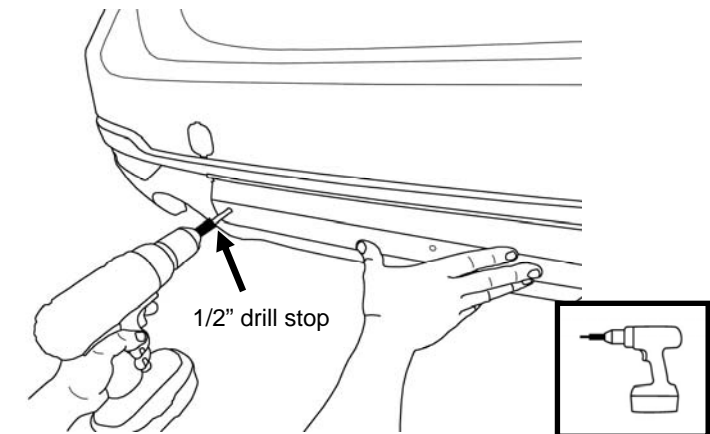

1/2" drill stop

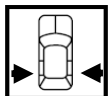
6  Align the inner push clips of the Bumper Under Guard (A) with the two inner holes drilled in Step 3, and align the two outer studs of the Bumper Under Guard with the outer holes drilled in Step 4. Insert halfway into holes to maintain position.

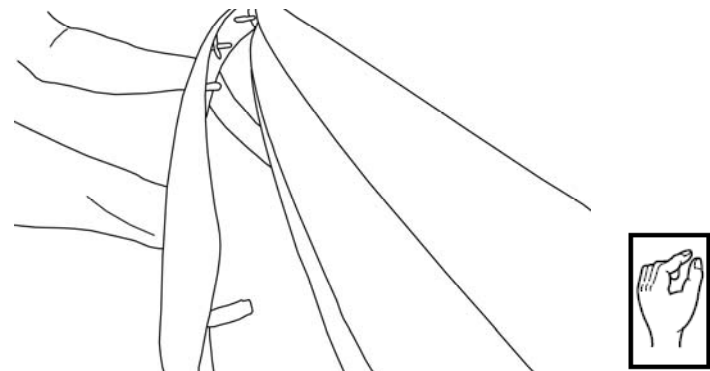

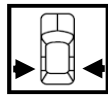
7  Press firmly at the two inner fastener locations to ensure full engagement of push clip fasteners.

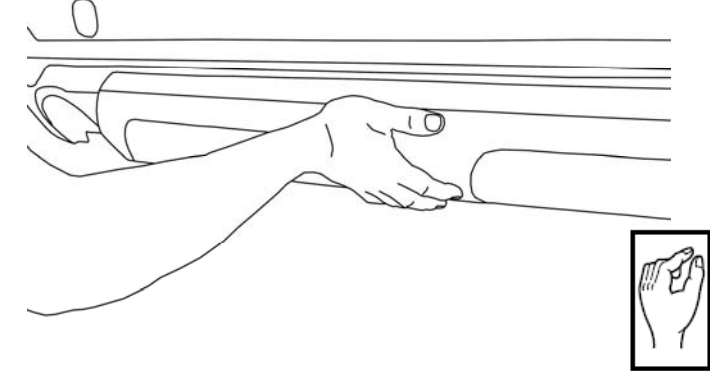

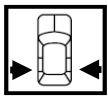
8  Start nuts (C) on the back of each of the two studs applied to bumper in Step 5. While holding part in place, torque nuts (C) to 20 inch pounds.

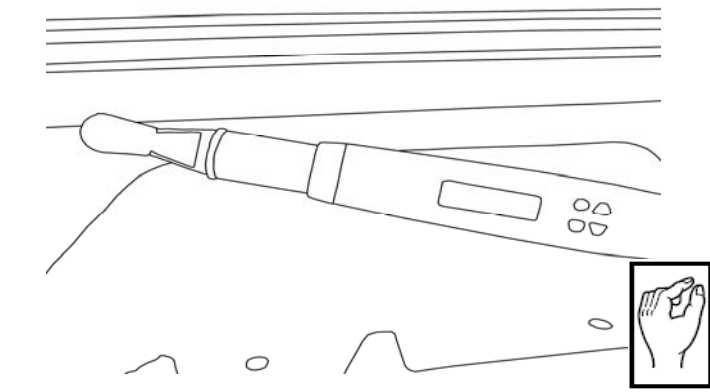

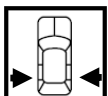
9  While holding part (A) firmly in place with no gap on ends, use 5/16" drill with 1/2" drill stop to drill (5) 5/16" mounting holes through the existing holes in the underside of the part and into the bumper at the indicated locations.

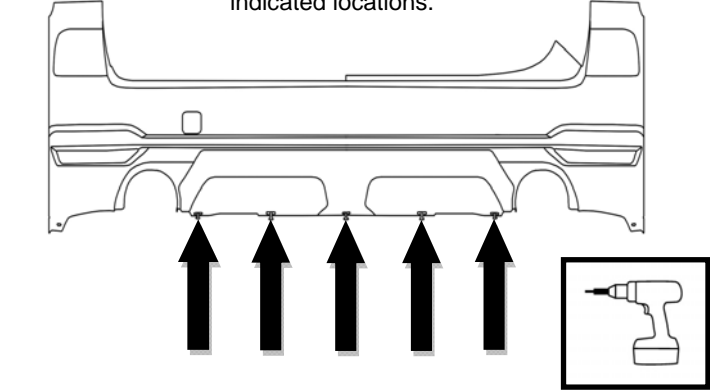

10



Install push retainer (B) in each of the five holes drilled in Step 8.

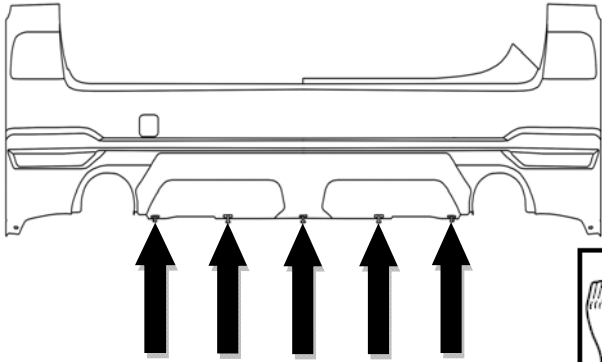

11

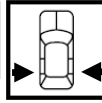

Installation is complete.

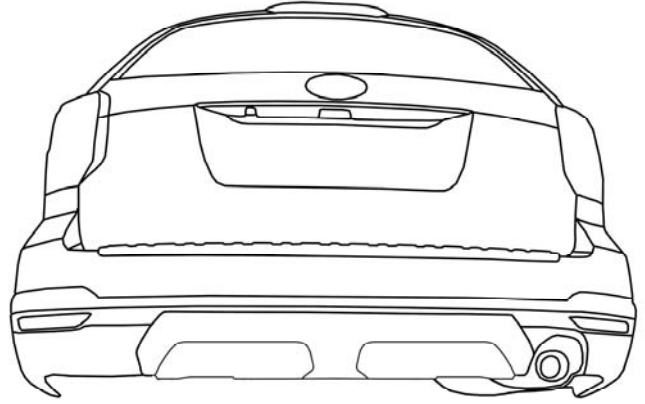



SUBARU

SUBARU

NUMÉRO DE PIÈCE : E551SSG300

*INSTRUCTIONS
D'INSTALLATION*

DESCRIPTION : ÉCRAN INFÉRIEUR DE PARE-CHOCS ARRIÈRE – FORESTER

CONTENU DE LA

A.

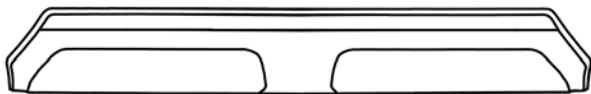

Écran inférieur de pare-chocs
arrière
x 1

B.



Cheville E551SSG310
x 5

C.

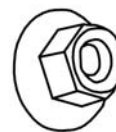

Écrou
E551SSG320
x 2

OUTILS REQUIS :

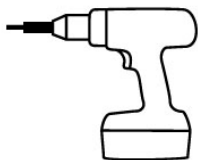

Perceuse avec
mèche de 5/16 po et
butée de perçage de
1/2 po

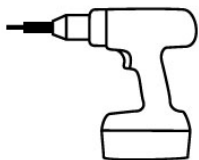

Perceuse avec
mèche de 1/4 po et
butée de perçage de
1/2 po



Clé dynamométrique
avec
douille de 10 mm

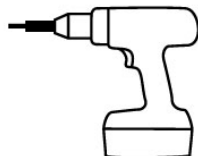

Perceuse avec
mèche de 3/8 po et
butée de perçage de
1/2 po

D.

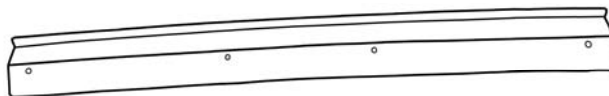

Gabarit de perçage
x 1



Lingette imbibée
d'alcool
x 1

NUMÉRO DE PIÈCE :
E551SSG300

VERSION :
01

DATE :
2013-01-31

SUBARU OF AMERICA

PAGE
5/8

SIGNIFICATION DES SYMBOLES :

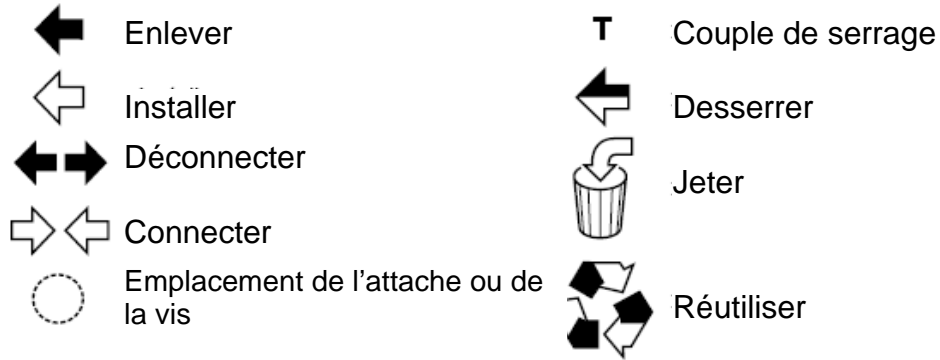

Préparation de la surface

1 Assurez-vous que les surfaces de montage (montrées ici) sont propres, sans tache, graisse ou résidu. Utilisez la lingette imbibée d'alcool isopropylique fournie. Inspectez le véhicule pour déceler toute trace de dommage avant de poser l'écran inférieur de pare-chocs. Avant de commencer, veillez à ce que le véhicule et l'écran inférieur soient à température ambiante. Si la température est inférieure à 16 °C (60 °F) ou supérieure à 43 °C (110 °F), laissez le véhicule reposer à l'intérieur jusqu'à ce que le pare-chocs et l'écran inférieur soient tous deux à température ambiante.

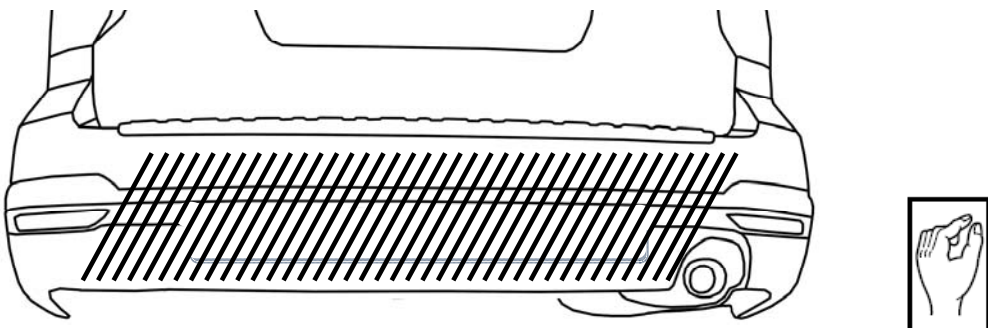

Installation de la moulure avant

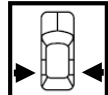
2  Décollez 1 ou 2 po des bandes de tirage du gabarit de perçage (D). Alignez le gabarit de perçage sur les lignes de carrosserie centrales et les lignes décoratives horizontales du pare-chocs. Appuyez légèrement le gabarit contre le pare-chocs pour le maintenir en place.

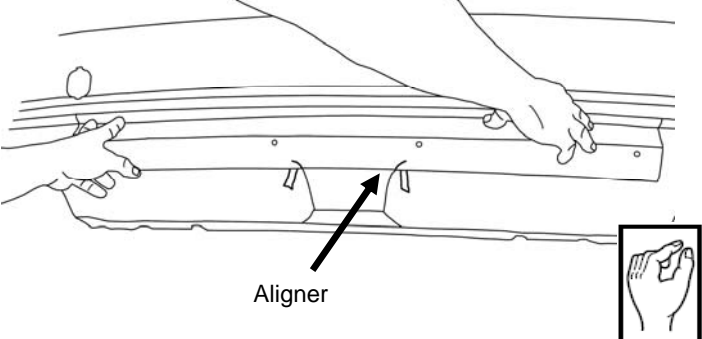

Aligner

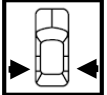
3  Avec un ruban à mesurer ou une règle, confirmez que le gabarit de perçage est centré sur le pare-chocs. Prenez la mesure de l'extrémité du gabarit de perçage au coin du boîtier du réflecteur.

Remarque : Si le gabarit n'est pas centré, enlevez-le et remplacez-le correctement. Une fois le gabarit centré, décollez les bandes de tirage restantes. Appuyez fermement sur chaque bande adhésive.

Du bord du gabarit au boîtier de réflecteur de coin

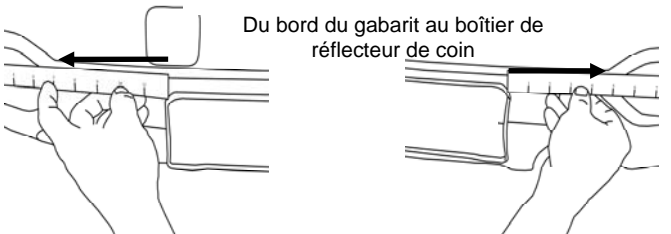

Côté gauche Côté droit

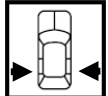
4  Avec la mèche de 1/4 po munie d'une butée de 1/2 po, percez deux trous dans le pare-chocs à travers les trous intérieurs du gabarit.

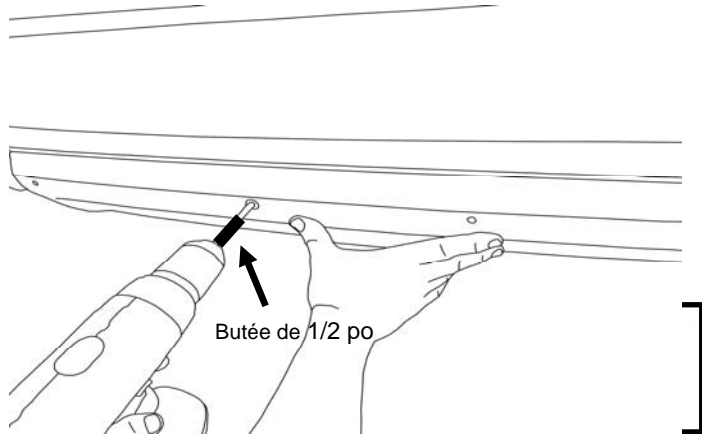

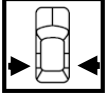

Butée de 1/2 po

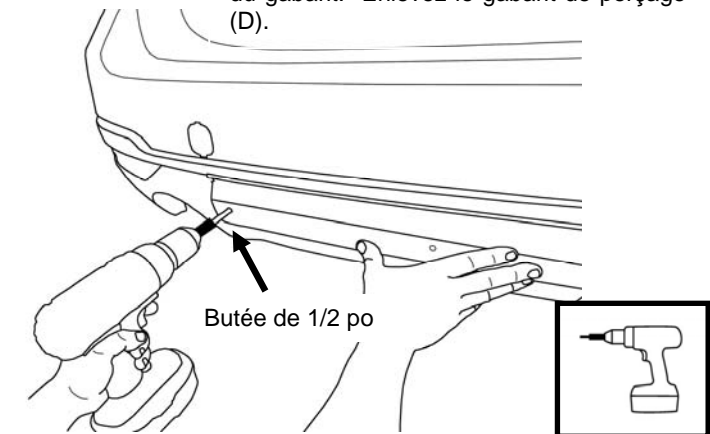
5  Avec la mèche de 3/8 po munie d'une butée de 1/2 po, percez deux trous dans le pare-chocs à travers les trous extérieurs du gabarit. Enlevez le gabarit de perçage (D).

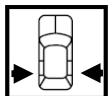

Butée de 1/2 po

6  Alignez les chevilles à pression intérieures de l'écran inférieur de pare-chocs (A) sur les deux trous intérieurs percés à l'étape 3, puis alignez les deux tiges extérieures de l'écran inférieur sur les trous extérieurs percés à l'étape 4. Insérez-les à moitié dans les trous pour positionner l'écran.

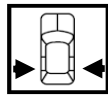

7  Appuyez fermement sur les deux chevilles intérieures pour vous assurer qu'elles sont complètement enclenchées.

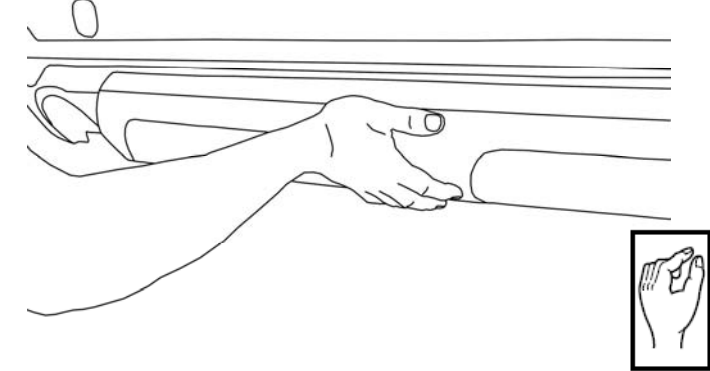

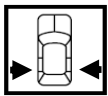
8  Commencez à visser les écrous (C) derrière chacune des deux tiges appliquées au pare-chocs à l'étape 5. En maintenant la pièce en place, serrez les écrous (C) à une pression de 20 lb-po.

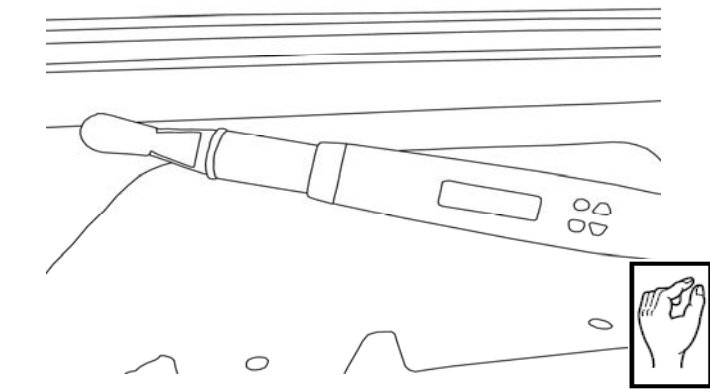

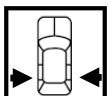
9  En maintenant fermement la pièce (A) en place, sans laisser d'interstices aux extrémités, utilisez une mèche de 5/16 po munie d'une butée de 1/2 po pour percer cinq orifices de montage de 5/16 po dans les trous existants sur la partie inférieure de la pièce jusque dans le pare-chocs, aux endroits indiqués.

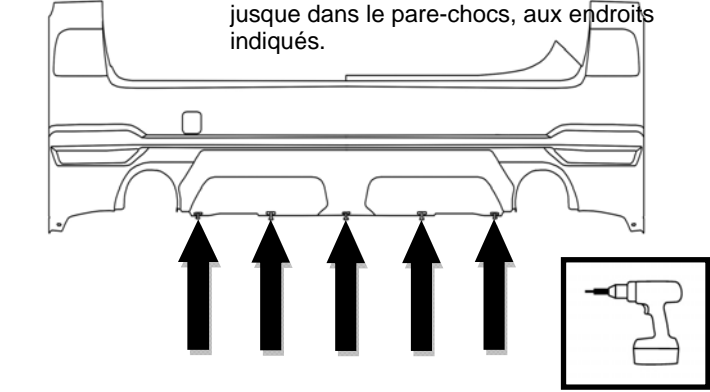

10



Posez une cheville (B) dans chacun des cinq trous percés à l'étape 8.

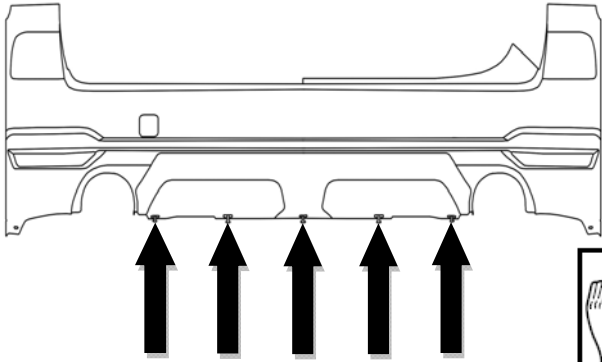

11

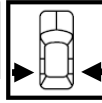

L'installation est terminée.

